

BRETON



CHAISE
AOR

COSTA RICA COLLECTION

BY
Choque Design

The AOR Chaise, winner of the gold medal at the International Design Awards 2023, boasts an innovative open seat that conveniently stores books or a laptop. Its design includes an adjustable backrest and versatile support, accommodating various body types. Inspired by the elegance of the 1960s and 70s, this chaise evokes a sense of comfort, well-being, and nostalgia..



CHAISE
AOR

BRETON

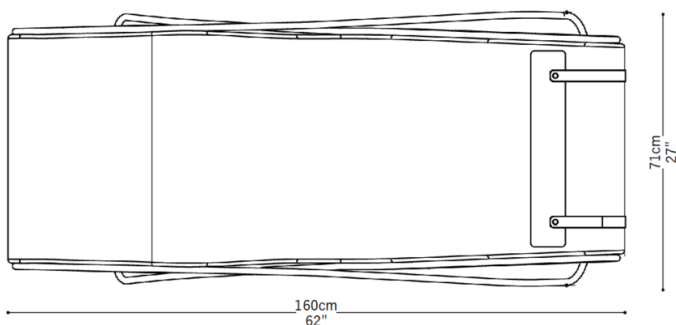
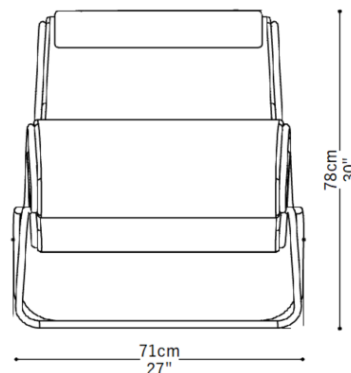
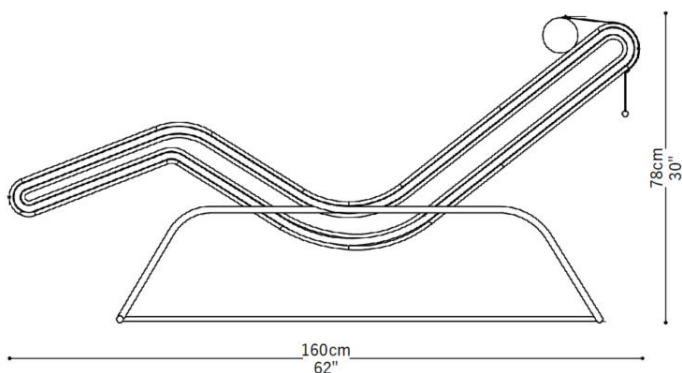

WARRANTY: 1 year from the delivery date.

PACKAGING: The legs are wrapped in polyethylene, and the structure is covered with flexible cardboard. The entire piece is then enclosed in a plastic bag, boxed, and crated for secure shipping

CHAISE
AOR

BRETON

Specifics:

- Polished stainless steel tubular frame, bent and curved
 - Durable materials with flowing curves
 - Counterweight cushion;



CHAISE
AOR

BRETON

 Polished stainless steel or painted carbon steel, bent and curved. Fixed back cushions upholstered in D33 foam.
Counterweight cushion;

Measures may vary slightly. We reserve the right to make changes without prior consultation.

CHAISE
AOR

BRETON